

DATASHEET

7028-RC SERIES

1 RU Shallow Depth, DC Powered Control Panels



For use with Sirius 800, Vega and Pyxis routers.

The 7028-RC range of shallow panels from Grass Valley® has been designed to meet the exacting requirements for hardware control panels used in simple or complex routing systems.

All panels are configured using proprietary RollCall® software launched via an applet addressed from a PC web browser.

The range consists of three 1 RU panels (one LED and two LCD). All types can be configured for X-Y or BPX operational modes.

RC shallow panels are independently configured over an IP network. A configuration file can be stored and copied to other panels (of the same type) or indeed loaded to a new panel when exchanging a faulty unit.



78-Key LED X-Y/BPX – 7028000RC



39-Key LCD X-Y/BPX + Rotary Control Knob – 7028251RC



21-Key LCD X-Y/BPX + Rotary Control Knob – 7028351RC

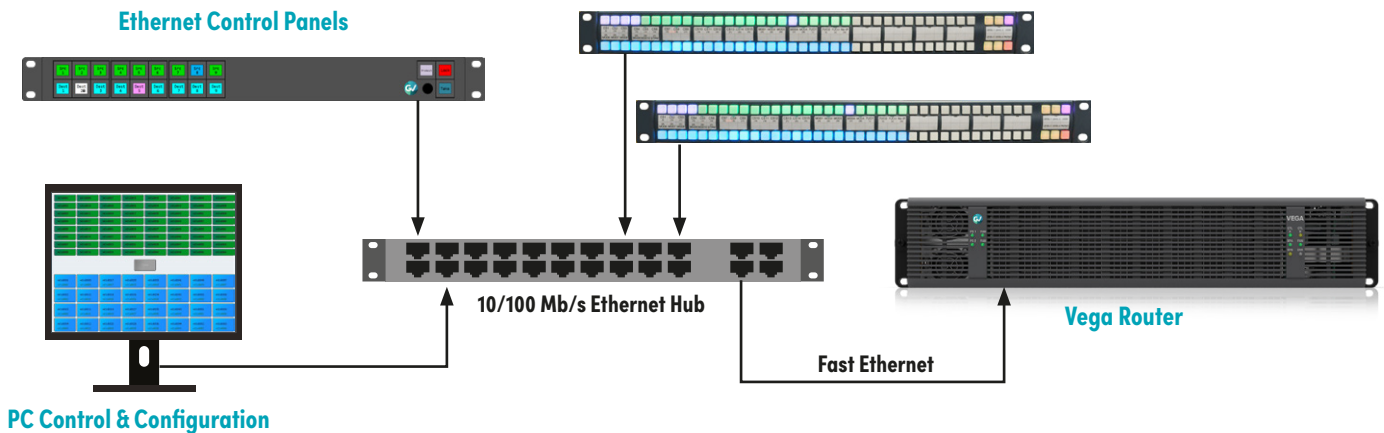

Key Features

- Lightweight ergonomic design
- Rack mounting depth of 50 mm (2")
- Fast Ethernet connection to router
- 12 GPIO ports
- Independent key allocation
- Programmable key color backlights
- Independent source and destination up/down paging keys
- Rotary control paging on LCD types
- LCD text options
- Dual 12V DC inputs with external converter(s) for mains supply
- Network port is POE (Power-Over-Ethernet) enabled

Configuration via Web Browser

Configuration of RC panels is implemented via a PC web browser. The panel applet will render on entering a default IP address. The panel address can be changed to your system requirements from the main configuration panel and the IP address of the router entered. Facility also exists to upgrade the panel configuration software over the internet should additional features be added. A set of intuitive menus allow you to custom build the panel layout to your specific needs. Once the layout has been determined, source and destination keys can be mapped to the appropriate ports on the router. For LCD panels, porting of source and destination names is automatic as soon as connection is established with the router controller. Changes to the panel configuration can be made while a system is operational by reactivating the applet.

7028xxxRC shallow control panels are compatible with Nucleus2 (246x) controllers as used in the Sirius 800 range of routers. They are also the recommended panel types for use with the Vega Asymmetric router (see example system on the previous page). Connection to a router for all RC panel types is IP Ethernet only (either directly or via a hub) over standard CAT5/6 cabling using RJ45 connectors. All the panels feature dual 12V DC inputs with external converters for mains supply.

For the 7028000RC panel printed legends are fitted between the two key rows under clear covers once the panel configuration has been defined.

Fully Flexible Source/Destination Key Positioning

RC panels provide free-form key function and positioning with the exception of just three which are fixed (see next page). All of the remaining keys can be independently configured as source (SRC), destination (DST) or paging keys (optional). Panels not requiring paging can use the additional keys as SRC or DST. Shown below is an LCD panel in X-Y mode using a horizontal SRC/DST key layout and another with a vertical layout. In the horizontal layout, for instance, it may be that an operator would prefer the DST keys to be in the top row with the SRC keys below. This is simple to configure in the RC panel range.

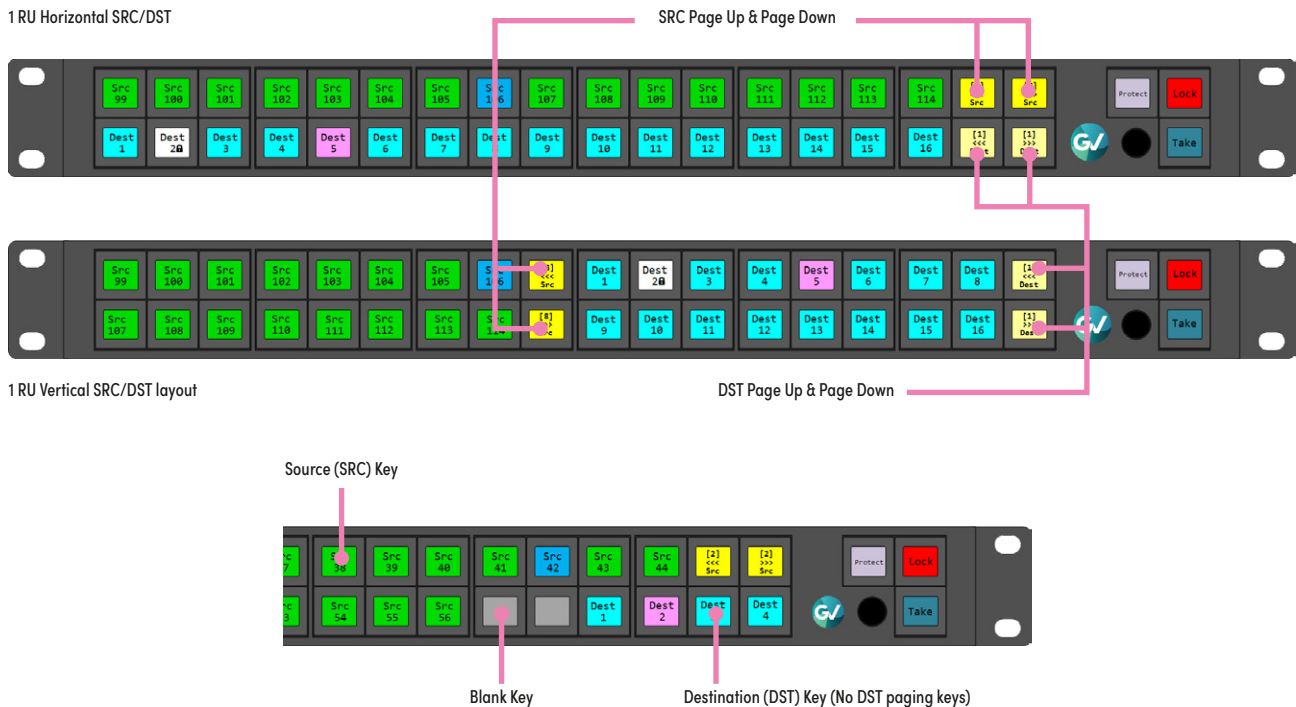

Fixed Keys & Rotary Encoder Switch (LCD only)

Positions of the Protect, Lock and Take keys (or buttons) are fixed on all panel types. If either or both the Protect and Take keys are disabled during configuration they will not display. Backlight illumination of the Lock/Unlock key can be configured as Red, Green or Amber for either status.

The LCD panel types include a Rotary Encoder Switch for paging as an alternative to (or in conjunction with) the Page Up and Page Down keys. Pressing the rotary encoder swaps its operating mode between source and destination paging.

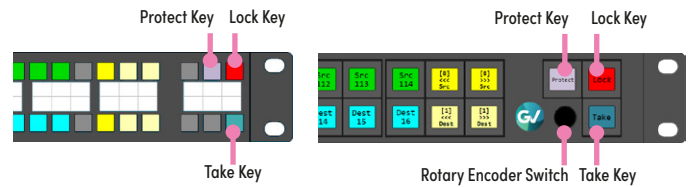

Example Paging Scheme:

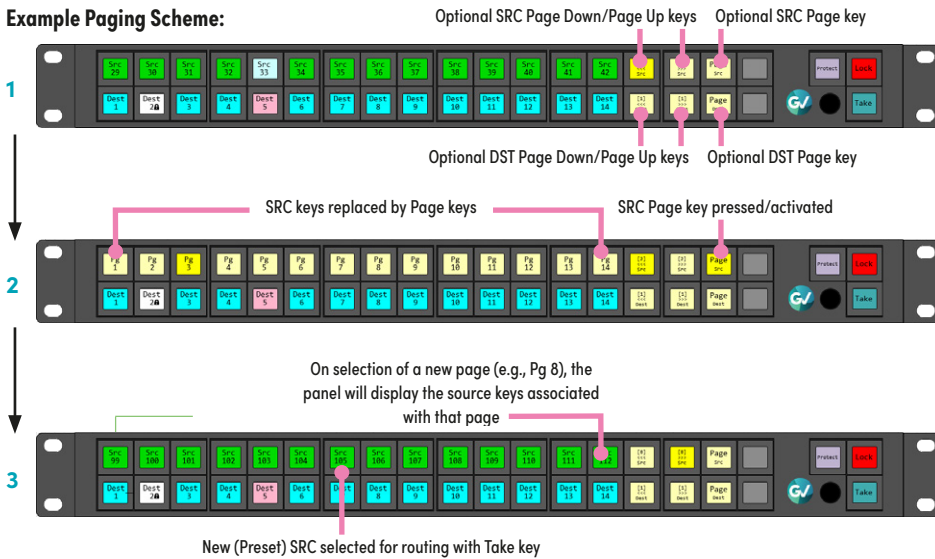

Paging — Optional Page Up, Page Down and/or Page Mode Keys

Optional keys that can be used with or without the Page Up and Page Down keys are the SRC Page and DST Page keys. On pressing the SRC Page key, for instance, all the displayed SRC keys will change to display an array of dedicated page keys. On selecting a new page the display will revert to the new set of SRC keys associated with that page.

The number of pages (and their names) can be set during configuration. Each page can be compiled from any of the router sources and in any order. Individual sources can appear multiple times on different pages. The equivalent is true for destination pages.

Button per Crosspoint (BPX) Operation

All RC panel types can be configured for X-Y or BPX (Button per Crosspoint) modes of operation. In BPX mode, each key can be individually assigned to a destination allowing either full panel schemes or any combination and number of Split BPX configurations. The example Split BPX panel shown to the right has been configured for three groups of BPX source keys assigned to destinations A, B and C.

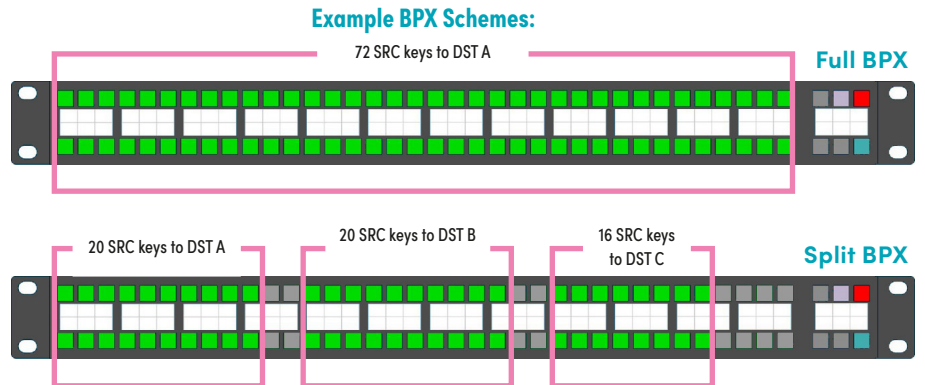

Other RC Series Panel Features

Custom Key Color and Brightness

All keys/buttons are backlit with RGB LEDs (LED & LCD panels). During configuration the color and brightness for each functional key type and state can be customized depending on user preference. Alternatively, factory preset value can be selected for each key type.

Illumination of Blank Keys and Text Insertion on LCD types

Assigned but unused keys can remain illuminated. Key color and brightness can be customized (as above) and LCD keys may include custom text.

Joystick Override via GPI Port

Twelve GPI override inputs are available on all panel types. During panel configuration each GPI is assigned a source for routing (on GPI activation) to the currently selected destination.

Dual Mode

The 7028000RC panel can be configured to work in either RC (RollCall) or WB (Workbench) operational mode.

The required mode can be selected very easily by the method outlined here.

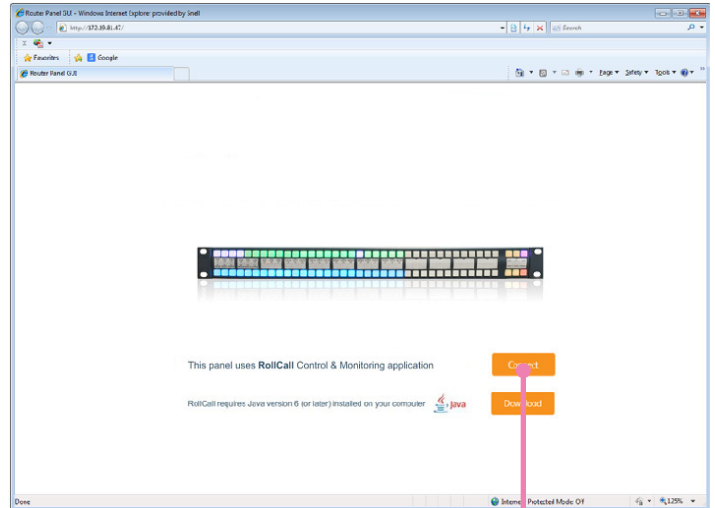

Use your PC network browser to launch panel applet and select "Connect."

When existing (default) mode is RC (RollCall), then configuration window below is displayed.

To enable WB (Workbench) mode select the "Legacy Mode" radio button and select "Restart."

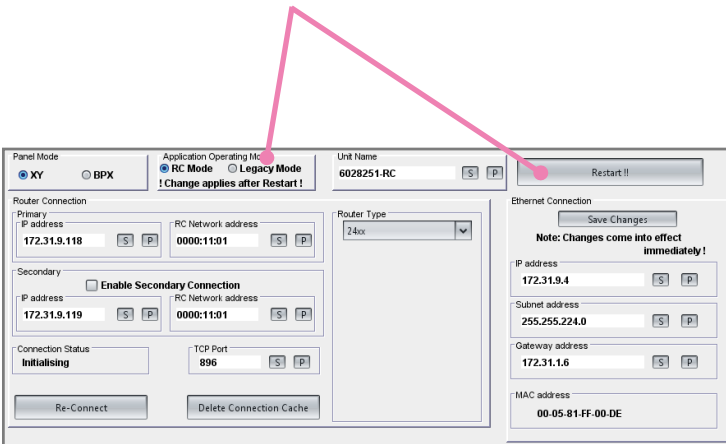

Access the panel again via the applet and the WB (Workbench) configuration window below will now replace the RC (RollCall) configuration window. To revert back select the "RC Mode" radio button and then select "Submit Mode."

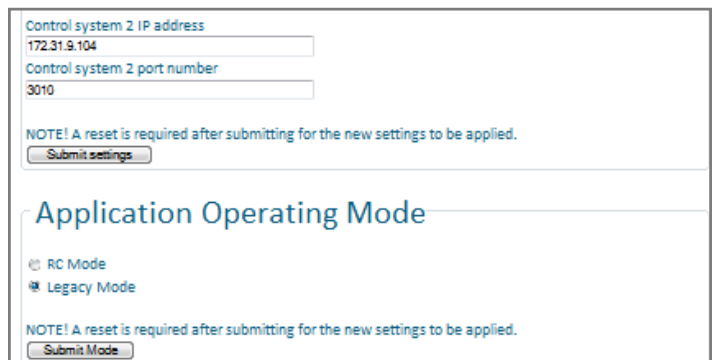

7028000RC LED Control Panel



Shallow Router Control Panels in Workbench Legacy Mode

The 7028000RC Router Control panel described in the remainder of this document is "Dual Mode." It can operate in RC (RollCall) or WB (Workbench) Legacy mode.

Selecting between the desired mode is described on the next page.

When configured for operation in Workbench Legacy mode, the 7028000RC panel depicted below is compatible with the Nebula, Nucleus (2450), 2330 and Nucleus2 (246x) range of router controllers.





Key Features

- Lightweight ergonomic design
- Ethernet or multidrop RS485 serial connection to router
- 12 GPIO ports
- Multiple configuration modes

After the panel configuration has been defined, printed legends are fitted either below or inside each key cap (dependent on panel type) for all the active keys. Legend key templates for each panel type are available for download from the router control panel section of our website.

There are 16 alternative operational modes to choose from including X-Y and BPX panel formats. All key LED illumination colors are as per the table.

Panel Key Colors (all panel types)

Key	Inactive		Selected	
Source	Green		White	<input type="checkbox"/>
Destination	Cyan		White	<input type="checkbox"/>
Level	Yellow		White	<input type="checkbox"/>
Lock	Orange		Red	<input checked="" type="checkbox"/>
Protect	Orange		Red	<input checked="" type="checkbox"/>



78-Key LED X-Y/BPX – 7028000RC

Workbench Legacy Mode

When configured for operation in Workbench Legacy mode, the 7028000RC panel depicted above is compatible with the Nebula, Nucleus (2450), 2330 and Nucleus2 (246x) range of router controllers.

There are 16 optional panel modes available. The desired mode is selected using the configuration switches on the rear of the panel. The outline images and key descriptions for modes 1 to 16 are shown below.

The routers controller's database is configured using Workbench C&M software to map source and destination keys to the appropriate router input and output ports.

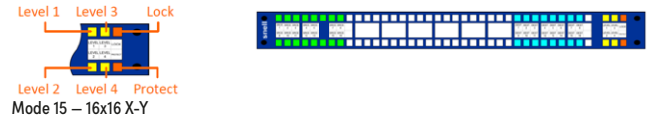
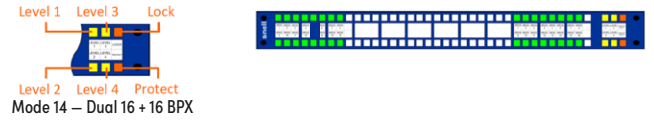
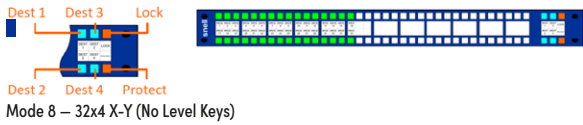

Specifications

Ethernet Control

Physical Layer: Ethernet

Standards: 10/100 Base-T Mb/s

Protocol: TCP-IP

Connector: RJ45 (x1)

GPIO (All types)

Physical Layer: +12V, 0.2A output

Connector: 15-way D female/screw lock

Serial Port Control (WB Workbench only)

1 RU Panel types: 7028000RC, 7028100RC & 7028201RC only

Physical Layer: RS-485

Connector:

- 9-way D female/screw lock (x2)
- Select Hi-Z (Loop-thru) or Terminate. Set via IP applet

Configuration (WB Workbench only)

Rotary Hex Switch 1: RS-485 Address

Rotary Hex Switch 2: Key Configuration

Rotary Hex Switch 3: Key Brightness

Rotary Hex Switch 4: RS-485/Ethernet Select

Resets

CONFIG Switch & LED: Restores Factory IP Address

RESET Switch & LED: Panel Reset

Physical

Mounting Height: 1 RU

Height 1 RU: 43.6 mm

Width: 448 mm

Depth: 50 mm (behind mounting face)

Weight: <1 kg (2.2 lbs.) max. (all types)

Environmental

Operating Temperature: 0°C to 40°C (32°F to 104°F)

Maintained Spec.: 0°C to 30°C (32°F to 86°F)

Storage Temperature: -20°C to 80°C (-4°F to 176°F)

Relative Humidity: 5% to 95% (non-condensing)

Cooling: Natural convection

Power

Connector: DC Jack or RJ45 (POE)

Voltage (DC Jack): +12V DC \pm 10%

Voltage (POE on RJ45): +42.5V to +57V DC

DC input power: 13W max.

Compliance

EMC – Emissions: EN55103-1 (EU), FCC Part 15 (USA)

EMC – Immunity Safety: EN55103-2 (EU) EN60950 (EU), UL1419 (USA)

Hazardous Material: RoHS-6 (UK) – Complies with EU Directive

1 RU Rear View – All Types

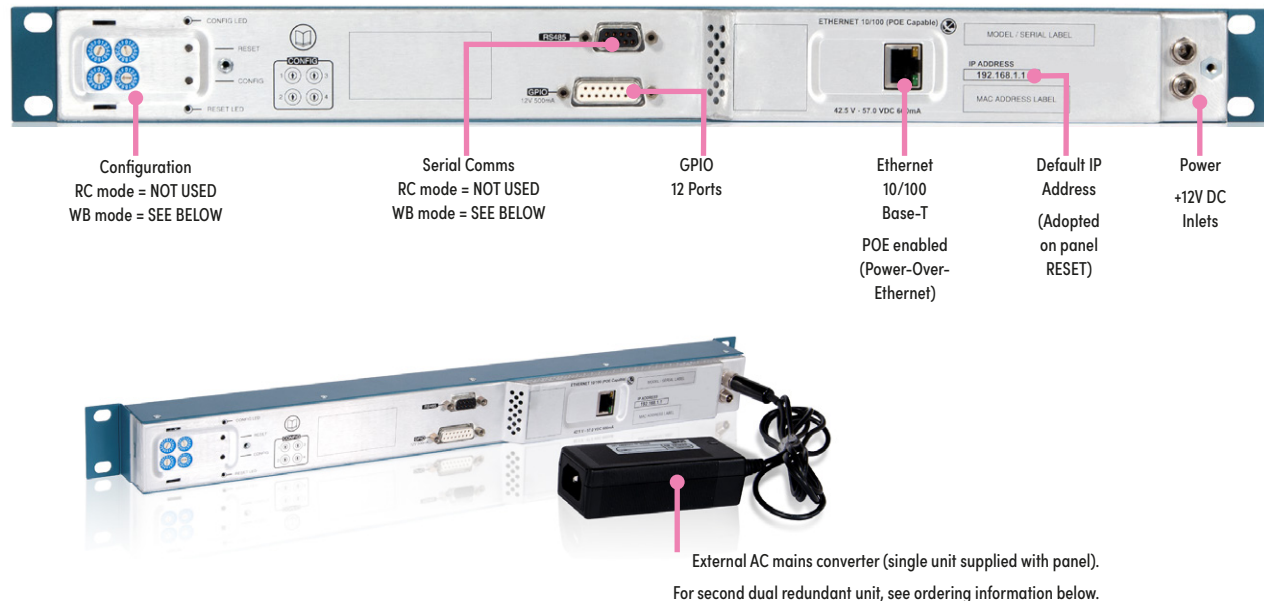

Ordering

7028000RCSB

1 RU 78-key LED Control Panel

7028251RCSB

1 RU 39-key LCD Control Panel with Rotary Encoder Knob

7028351RCSB

1 RU 21-key LCD Control Panel with Rotary Encoder Knob

INSY-PSU-EXT

External AC mains adapter. Single unit supplied with panel. (Additional unit must be ordered if dual redundant operation is required).

This product may be protected by one or more patents. For further information, please visit: www.grassvalley.com/patents

DS-PUB-3-0961A-EN

Grass Valley®, GV® and the Grass Valley logo are trademarks or registered trademarks of Grass Valley USA, LLC, or its affiliated companies in the United States and other jurisdictions. Grass Valley products listed above are trademarks or registered trademarks of Grass Valley USA, LLC or its affiliated companies, and other parties may also have trademark rights in other terms used herein. Copyright © 2021, 2023 Grass Valley Canada. All rights reserved. Specifications subject to change without notice.

www.grassvalley.com Join the Conversation at GrassValleyLive on [Facebook](#), [Twitter](#), [YouTube](#) and Grass Valley on [LinkedIn](#)